

**Engineered to order solutions**  
Retrofits for grinding mills



Improve  
your assets  
without major  
investments



## Engineered to order solutions Retrofits for grinding mills

A recurring need from our customers is to restore and improve the performance of existing grinding mills without major investment.

Our first grinding mill supplied  
date back to late

→ 1950's

So far we delivered more than

→ 8,000

grinding mills globally

Our engineered-to-order solutions can help either to restore your grinding mill to its original condition by replacing damaged parts or to adapt it to new technology by implementing design modifications and installing modern components.

When compared to the acquisition of brand new equipment, implementing modifications dramatically shortens lead times - and is much more cost effective. Depending on what the job entails, it can be done within your own facility or at the nearest Metso repair center.

By incorporating our engineered-to-order solutions, you get the best results from your grinding mill, regardless if it is a current or previous model.

### Improved equipment operation

Through the incorporation of latest technologies available in modern grinding mills, the operation of your existing equipment can be improved significantly from maintenance, safety, and reliability standpoints. A realistic picture of the cost effectiveness of our engineered-to-order solutions can be specifically measured through equipment availability, production, and uptime.

### Unique know-how

Our experience learned in the field along with our equipment knowledge, which includes Metso and all our predecessor brands, helps us understand the fundamental requirements of your operation. From that understanding, we can determine the most suitable changes to implement in order for you to reach your production goals.

### Outsmarting obsolescence with an engineered-to-order solution

While gear spray systems may not be the first thought when considering wear parts to replace, it should be on the maintenance foreman's "pay close attention to" list.

Overheating a mill's gear and pinion can cause extensive and very costly damage. Lead times on parts can be quite long, with down time contributing significantly to repair or replacement costs. Often the equipment is outdated and no longer available.

We have a wide-range of ability incorporating our engineered-to-order lubrication systems into existing mills. Developing ways to improve our equipment's reliability and ease of repair is ongoing. Don't overlook a simple, cost-effective, and low-maintenance solution to a prospectively expensive problem.



Engineered to order retrofits cover assembly design modifications and drive train modifications as well as automated systems.

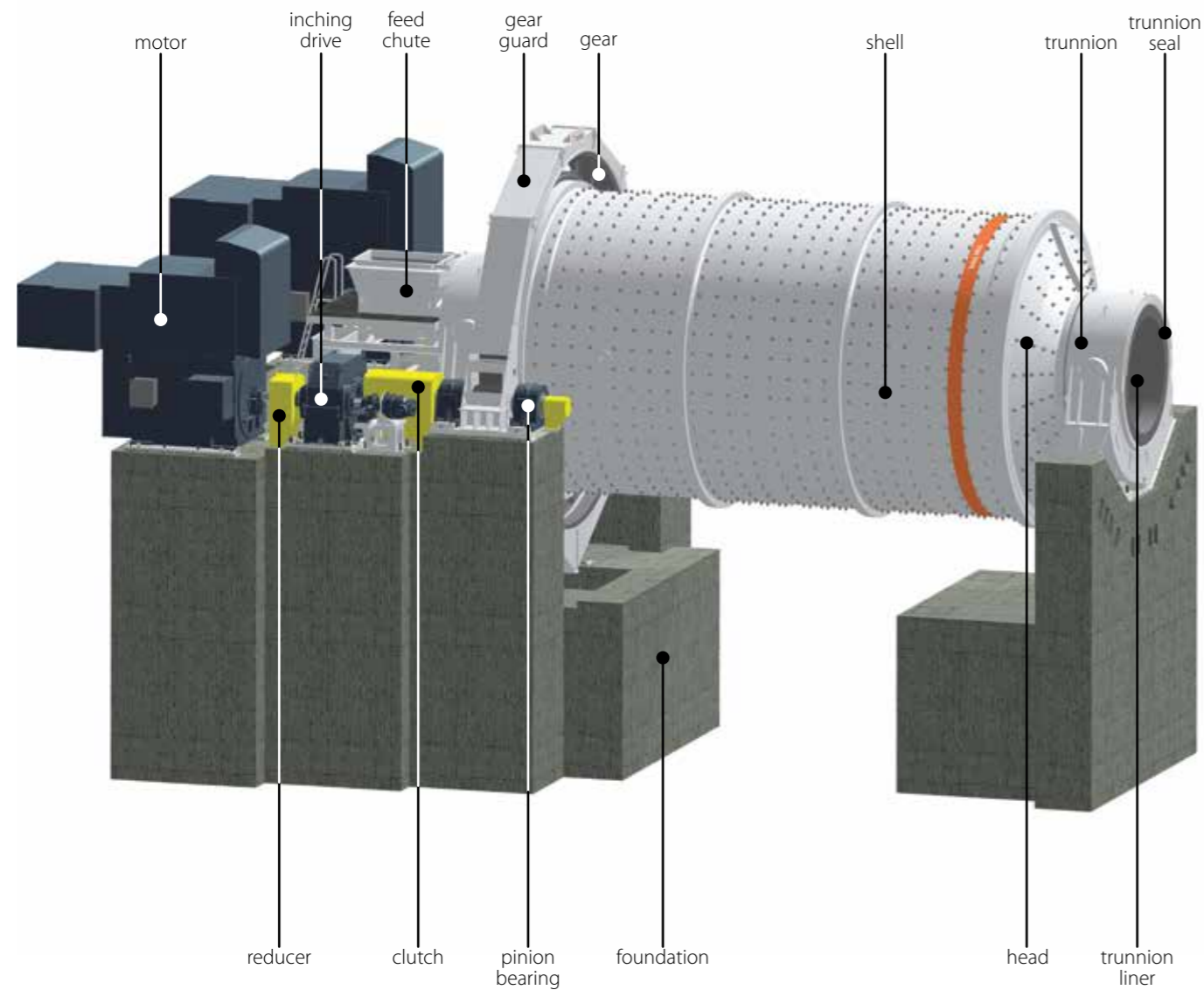

Illustrative example of components covered by engineered to order solutions in a ball mill.



## Assembly design modifications

### Foundation survey and repair

Foundations of older equipment can be surveyed to assess the condition of the concrete, which can deteriorate over time from movement and/or vibration. New soleplates can be used to modify and repair the foundation, helping to eliminate future problems.

### Overall inspection and basic assessment

Cracks, missing bolts, wash and wear, excessive vibration, oil or slurry leaks are all examples of what can be discovered during an overall mill inspection. Engineering evaluation complements the inspection in order to troubleshoot the causes.

Recommendations are made to remedy the situation. In some cases, it may be best to do nothing but monitor on a continual basis.

### Grout injection

Injecting or pumping grout is an effective way of filling-in a cavity or securing a loose trunnion liner within a trunnion. The expertise of grout injection requires designing the inlet and outlet ports strategically to ensure smooth filling of the cavity as well as venting of the trapped air.

### Lifting arrangements

Lifting heavy parts requires proper design and sizing of lifting lugs, eye bolts, etc. Lifting arrangement drawings need to accompany the lug fabrication drawings in order to make sure the lug loading assumptions are not violated. All lug and lifting arrangement drawings are checked and certified by a Metso design engineer.

### Structural erection supports

When erecting or raising a mill, the design of custom structural erection supports ensures a timely and safe installation. Step-by-step erection instructions are included in the drawings provided by Metso. All erection support structures and erection drawings are checked and certified by a Metso design engineer.

### Trunnion seal upgrade

Older mill trunnion seals and bearing housings can be upgraded to accommodate Metso's current standard of grease purged triple lip seals. For example, worn or damaged piston-ring seal grooves can be eliminated by filling the grooves with epoxy and then shrink-fitting sleeves on the inboard and outboard ends of the journals. Bearing housings are then modified to accommodate the triple lip seals.

### Gear guard upgrade

Old gear guards can be upgraded or replaced with Metso's current designs. Viewing ports, temperature sensors, newest seals, and upgraded gear spray systems can be added to prolong the lives of the gears and pinions, monitor gear performance, as well as to facilitate inspection.

### Trunnion liner repair

When the fit between the trunnion and the trunnion liner is worn, the trunnion liner becomes loose and the bolts attaching the trunnion liner to the trunnion start breaking. Rather than machining the trunnions on site, a new machined sleeve is centered and grouted in place.

This becomes the new trunnion bore for a slightly smaller, new trunnion liner.

### Structural parts remachining

Off-site machining is an effective cost and time means of refurbishing large structural components such as trunnions and heads. Controlled machining in a machine shop environment provides the most accurate clean-up of bearing surfaces, flanges, re-drilling of holes, etc. New drawings are provided by Metso outlining the scope of machining with clearly identified maximum material removal limits and inspection criteria.

### Site machining

Site machining is an effective cost and time means of refurbishing large structural components. Site machining is generally used after weld repairing large components at site to skim-cut flanges and bolted connections that have distorted or lost their machined surfaces.

### Wear, wash, and crack evaluation

Wear and wash measurements on structural rotating components are assessed by Metso structural engineers to determine whether a mechanical reinforcement or a replacement is necessary or not. Similarly, cracks can be evaluated for their rate of growth. Treatments and inspection plans are proposed.

### Finite element analysis (FEA)

Structural evaluation using FEA techniques is a very effective tool to design new and retrofit equipment, to evaluate damage caused by slurry wash, or to verify the effectiveness of mechanical reinforcements such as adding gussets and wrapper plates. FEA results are continuously verified against strain-gauge stress measurements on actual operating equipment and the in-house developed methods are refined frequently.

### Site shell welding

Worn or cracked shells can be weld repaired at site. Reinforcing gussets can also be welded to minimize distortion due to welding and to add structural strength. Over time, welding procedures have been refined and complemented with weld grinding and shot-peening.

### Structural repair design

Structural repair design typically involves identifying the cause of failure, then improving the design by increasing thicknesses and/or eliminating the stress concentrations. Occasionally, material or manufacturing methods can be changed, and the engineering specifications tightened. Special consideration is given to minimize changes to other existing components.

### First-of-its-kind, complex repairs

First-of-its-kind, complex repairs are usually needed when a crack or severe wash is discovered in the rotating structural components, or when a design improvement is necessary to change operational parameters such as increased mill loading. In all cases, providing a timely response and finding a creative solution to get the equipment back in operation is of utmost importance.



## Automated systems

### Pinion temperature monitoring

The pinion temperature monitoring system uses differential temperature checks across the pinion face to ensure proper pinion alignment. Automatic sensing and continuous condition monitoring is accomplished through infrared sensor technology (4 to 20 mA to PLC or DCS). The system uses low-maintenance parts for operational efficiency and is customizable to fit most gear guards.

### Trunnion bearing RTD installation

Older trunnion bearing housings either do not have RTDs to measure bearing temperatures or the RTDs are embedded in the bearing sleeve making maintenance very difficult. These bearing housings can be retrofitted with RTDs using 100 ohm sensor technology, which rides directly on the bearing surface. They provide automatic, continuous, and accurate differential temperature checks of the trunnion journal surface to ensure alignment. New viewing/inspection ports can also be added to facilitate bearing inspection and RTD maintenance.

### Trunnion bearing lubrication system

Replacing an outdated lubrication system can extend the life of bearings and trunnions. Recent design improvements to the trunnion bearing lubrication system are based on operational experience. The system automatically maintains constant temperature and even flow as well as improves the efficiency of the oil filtration process. The modern instrumentation is compatible with existing DCS, and the newly added state-of-the-art components are more readily obtainable. The system can be either water or air cooled and includes an option for lubrication of pinion bearings. Hydrostatic systems are also available.

### Gear spray lubrication systems

The solid-state control panel mounted in the vicinity of the gear accomplishes the control of the gear spray system. The Metso supplied PLC control panel includes an HMI for configuring the number of spray counts, the time for the spray counts to be completed, and the time between spray cycles.

## Drive train modifications

### Gear and pinion magnetic particle inspection

Magnetic particle inspection (MPI) of the gear and pinion teeth as well as the gear structure is the most effective way to determine cracks and surface damage. An engineering evaluation complements the inspection as to whether the gear or pinion is fit to run with or without repair, or if either should be flipped or replaced.

### Hydraulic inching drive installation

Mills without an inching drive can be retrofitted with hydraulic inching drives. These units can be permanently bolted to the foundation, or they can be shared between similar mills. If shared, they must have a torque arm that locks the unit to the foundation when operating.

### Soleplate upgrade

Some older mills do not have shear keys on the pinion or main bearing soleplates. If the foundation or the grout deteriorates, hold down bolts and soleplates can start moving, causing misalignments. Soleplates can be upgraded by adding shear keys, and refurbished by re-machining the flat surfaces. Further modifications of the soleplates allow easy installation of trunnion and pinion bearings.

### Retrofit filtering lube unit installation

Older mills that run on self-lubricated hydrodynamic bearings can be retrofitted with filtering lube units designed by Metso. Separate units are installed for feed and discharge ends. These systems use the bearing housing as the oil reservoir and are mainly used to filter the bearing oil to prolong bearing and oil life. As an option, these units can also provide high-pressure oil to lift the mill for start-up. Temperature controls are integrated with mill start-stop logic.

### Gear calculations and expertise

Gear and pinion sets can be checked and designed completely by Metso engineering. This expertise is used in crack-and-wear evaluation of the teeth, re-machining existing gears, as well as in designing new replacement gears.

### Gear design upgrade

Mill gears and pinions can be replaced with an improved design and/or material. Gears can be designed either in steel or nodular iron. To shorten delivery time, a cast gear can be interchanged with a fabricated gear. Gear teeth can be re-cut to save cost and improve delivery. Size and shape of windows and ribs can be improved. Herringbone or spur gears can also be replaced with helical designs. Seals can be upgraded to prolong gear life.

### Metso's engineered to order (ETO) group shows off its expertise

The expertise of Metso's Engineered-to-order (ETO) grinding solutions was exhibited in full force during a recent service call from a southwestern US mining operation, by providing extensive modifications to a lime slaking mill.

Working with the mine to develop an ideal solution for the existing 8-by-3-feet Hardinge conical ball mill, the ETO grinding team proposed a redesigned mill including shell, trunnions and trunnion bearing assemblies - all engineered to utilize the existing foundation and drive arrangement. To reduce maintenance and increase operating efficiency, the retrofit included: eliminating old riveted joints, adding rubber liners, updating gear/ pinion set, updating lubrication system and also adding trunnion liners with spirals.

In addition to the proposed solution, the Metso team - with support from the Field Service Engineer - provided our client with a detailed outline of each step of the retrofit. Additional measures (e.g., checking the lift before running the mill, installing a new gear guard) were taken to ensure optimal safety. And to minimize downtime and help guarantee efficiency over time, the mine is keeping spare parts, filters and trunnion seals in stock.

As illustrated by this project, the Metso team provides comprehensive support to ensure customer goals are met. For the mine operators, Metso was able to deliver an updated lime slaking mill that provided across-the-board operational improvements: from efficiency to safety.



We serve all grinding mills sold from our predecessor companies and brand names:

- Allis Chalmers
- Allis Mineral Systems
- Boliden Allis
- Denver Equipment
- Dominion
- Hardinge
- Koppers
- Kennedy Van Saun (KVS)
- Marcy
- MPSI
- NEI
- Sala
- Svedala



**Metso Minerals Industries, Inc.** , 2715 Pleasant Valley Road, 17402 York-PA, USA, tel +1 717 843 8671



QR code for smartphones